



Actual mirrors differ to those shown

Model	NPR250S	NPR250S AMT	NPR250M	NPR250M AMT	NPR300S	NPR300S AMT	NPR300M	NPR300M AMT
Code	NP101	NP102	NP103	NP104	NP105	NP106	NP107	NP108
Configuration	4 x 2							
Gross Vehicle Mass	4,500 Kg				5,500Kg			
Gross Combination Mass	8,000 Kg				9,000 Kg			
Maximum towed mass braked	3,500 Kg							
Maximum towed mass unbraked	750 Kg							
Gradeability at GVM/GCM (1st gear)	53/24%	59/26%	53/24%	59/26%	40/20%	44/22%	40/20%	44/22%
Est. Engine RPM @ 90 Km/h	2065	2050	2065	2050	2065	2050	2065	2050
Turning circle kerb to kerb (m)	9.6		11.7		9.6		11.7	

DRIVELINE SPECIFICATIONS

Engine Model	4HK1-TCN							
Type	4 cylinder 16 valve, gear driven SOHC. Euro IV exhaust emission compliant							
Displacement (cc)	5,193							
Compression ratio	17.5:1							
Max power (DIN Nett)	114kW 155PS (JIS Gross 118kW, 160PS) @ 2600 RPM							
Max torque (DIN Nett)	419N.m (JIS Gross 434N.m) @ 1,600 – 2,600 RPM							
Transmission model	MY5T	MY6S	MY5T	MY6S	MY5T	MY6S	MY5T	MY6S
Forward gears	5	6	5	6	5	6	5	6

KERB MASS* (kg)

Front	1,660	1,680	1,670	1,690	1,660	1,680	1,670	1,690
Rear	765	805	785	825	765	805	785	825
Total	2,425	2,485	2,455	2,515	2,425	2,485	2,455	2,515

*Estimate with coolant, oils, tools and 10 L of fuel

DIMENSIONS (mm)

WB: Wheelbase	2,765	3,365	2,765	3,365
OAL: Overall length	5,385	5,985	5,385	5,985
EA: Rear of engine to rear axis	2,080	2,680	2,080	2,680
CE: Cab to rear of frame	3,702	4,302	3,702	4,302
ROH: Rear overhang	1,510			
RT: Rear track	1,650			
ORT: Overall rear tyres	2,080			
FW: Frame width @ Rear	850			
RFH: Frame height at rear axis	750			
BOC: Back of Cab Clearance	112			

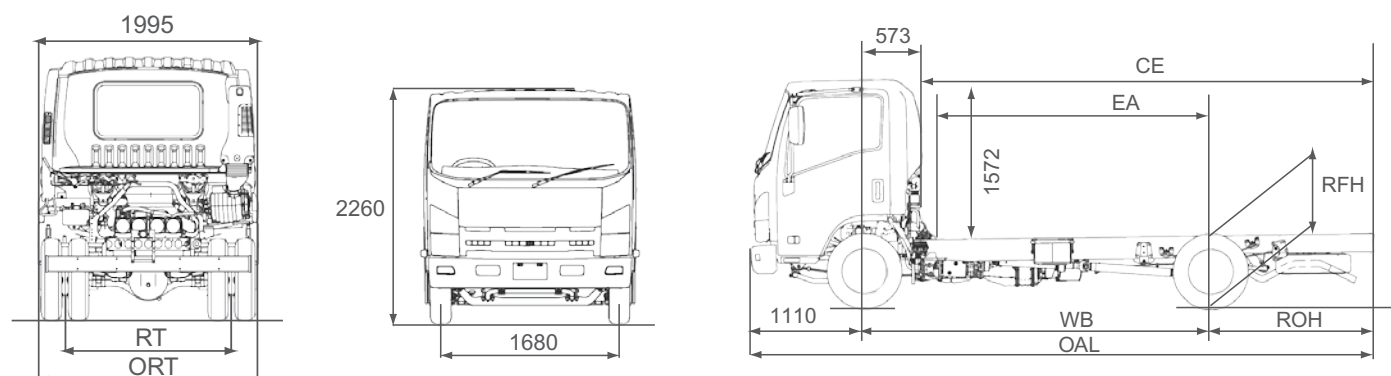

Drive Line Specifications

Engine-ISUZU 4HK1--TCN

- Bore x Stroke 115mm x 125mm

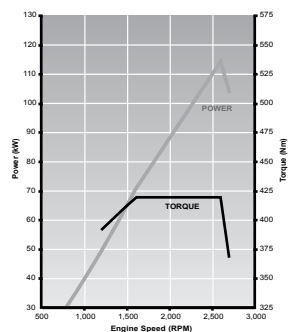

Emission control system

- Euro IV with cooled Exhaust Gas recirculation and Diesel Particulate Diffuser (DPD)

Lubrication

- Spin on element oil filter
- Plate type oil cooler
- System capacity approx 13 litres

Cooling system

- Temperature controlled viscous fan hub
- Approx coolant capacity 18 litres

Fuel System

- Electronically controlled, direct injection high pressure common rail
- Lockable fuel cap
- Steel fuel tank capacity 100 litres
- Water in fuel sensor

Air Intake System

- Electronically controlled variable nozzle turbo charger with Air to Air Intercooler
- Rear of cab vertical air intake

Clutch (manual models)

- Auto adjusting hydraulic control with vacuum assistance.
- Single plate 325mm diameter
- Total lining area 966 cm²

AMT

- Fully automated hydraulically controlled wet clutch and fluid coupling with lock up and oil to air cooler
- Approx system capacity 6.6 litres

Transmission: MYY5T Manual models

- 5 speed manual synchromesh on gears 1 through 5
- PTO provision on LHS of the transmission case countershaft driven.
- Approx oil capacity 2.8 litres

Ratios :1

- 1st 5.315, 2nd 3.053, 3rd 1.655
- 4th 1.00, 5th .721, rev 5.701

Transmission MYY6S AMT models

- 6 speed Automated Manual Transmission with both fully automatic and sequential shift manual modes
- PTO provision on LHS of the transmission case countershaft driven.
- Approx oil capacity 3.5 litres

Ratios :1

- 1st 5.979, 2nd 3.434, 3rd 1.862,
- 4th 1.297 5th 1.00 6th .750 Rev 5.701

Front Axle: ISUZU F031

- Reverse Elliot I beam
- Capacity 3,100Kg

Rear Axle: ISUZU RO66

- Full floating Banjo type
- Capacity 6,600Kg
- 320mm diameter ring gear
- Approx oil capacity 4.3 litres
- Ratio; Man 4.30:1, AMT 4.10:1

Load limit Kg (on ground)

Front	Rear
2,360	4,480

Chassis Specification

Front Suspension

- Single stage, alloy steel, taper leaf 1300x70x16.5-1, 18-1, constant 128 N/mm
- Stabiliser bar
- Double acting hydraulic Shock absorbers

Rear Suspension

- MLS main, TLS helper
Main 1300x70x11-2, 17-2, constant 145N/mm
Helper 850x70x17.5-1 combined 427N/mm
- Stabiliser bar
- Double acting hydraulic shock absorbers

Steering

- Power assisted recirculating ball
- Gear ratio 20.9:1
- Turns lock to lock 5.4

Brakes

- Auto adjusting front disc and rear drum brakes with dual circuit hydraulic control, vacuum assistance and Electronic Brake distribution
- ABS and ASR (traction control)
- Hill Start Aid - except AMT
- Front discs 295mm x 40mm, ventilated
- Rear drum 320mm x 100mm
- 190mm diameter drum rear of transmission mounted park brake
- Vacuum controlled exhaust brake

Chassis Frame

- Cold rivetted ladder frame. SAPH440 weldable steel parallel side members
- Frame side rail dimensions(mm) 216x70x6

- *Please refer to the Isuzu Body Builders guide for chassis modifications and body fitment*

Wheels and Tyres

- 16x5.5Jx116.5mm five stud steel wheels
- 195/85R16 114/112L tubeless tyres
- Wheels painted silver
- Frame mounted spare wheel and tyre

Electrical System

- 24 volt negative earth system
- Alternator 50 amp
- Battery 2 x 80D26L, 582CCA @-18c

Cabin Specifications

Cab Exterior

- All steel construction, high tensile steel used for cab underframe and door side impact beam reinforcement.
- Manual cab tilt to 45° with torsion bar assistance
- Liquid filled front and rear cab mounts
- Heavy duty non slip cab entry steps
- 70° opening doors
- Cab mounted front of cab main mirrors
- Polycarbonate bumper with steel backing frame
- Halogen multi reflector headlamps incorporating turn signal, additional door mounted side indicator lamps
- Roof mounted end position lamps
- Combination brake, turn, reverse and marker lamps, registration plate lamps, extended wiring harness, reverse alarm

Cab Interior

- Contoured adjustable driver's bucket seat
- Passenger front bench seat with 2 seat capacity
- 3 point ELR seatbelts in all outboard seating positions, drivers seatbelt fitted with pretensioner

Warranty

Vehicle: 36 months/100,000kms*
 Corrosion (Perforation): 36 months
 * Which ever occurs first. Subject to the terms & conditions detailed in the Owners manual Service and Supplement

- Lap belt in centre seat
- Driver side SRS including air bag
- Door and roof pillar entry assist grips
- Lined cab interior, padded roof lining and vinyl floor coverings
- LH and RH overhead storage shelf
- Height/reach adjustable steering column, soft feel urethane steering wheel
- Electric windows
- Central locking with remote keyless entry and engine immobiliser
- Twin cup holders, 24v cigarette lighter.
- Door mounted storage pockets
- LH side glove box
- Interior light
- Integrated air conditioning with 4 speed fan
- Radio/single disc CD with 2 speakers and auxillary input jack port
- 5 DIN sized compartments for storage or additional communication units

Instrument & Controls

- Speedometer with digital odometer and two tripmeters

Please refer to the Owners and Drivers Manual for more detailed operation, driving instructions and warnings

A policy of continual improvement means that the specifications are subject to change without notice. Contact your Isuzu dealer to confirm specifications

- tachometer, engine coolant temperature and fuel level gauges
- Two speed wipers with intermittent wipe mode
- Key operated engine start/stop and steering lock
- HSA slow/fast engagement control and on/off switch - except AMT
- ASR on/off switch
- DPD manual regeneration switch
- Cruise control - AMT only
- Multi display - AMT only
- AMT: slow/fast clutch re-engagement control, 1st gear selection, economy mode
- LH combination stalk: windscreen wipers, washers and exhaust brake
- RH combination stalk: turn signals and headlamps, cruise control - AMT only
- Warning lamps: check eng, oil pressure, ABS, SRS alternator charge, service brakes, park brake, water in fuel, seat belt unbuckled, check AMT - AMT only
- Indicator lamps: HSA-except AMT, warm up system, high beam, ASR, DPD status, exhaust brake, turn signals
- AMT: econo mode, 1st gear start, gear selection display
- Multi display:(AMT only) shows service interval, instantaneous and average fuel consumption, DPD bar chart, hourmeter, voltmeter, time/day/date and 40 - 120km/h adjustable vehicle speed warning