

SERIES

All images displayed in this document are for illustrative purposes only.

Specification Guide

NQR 88.19

Weight Rating

GVM 8,800 kg

GCM 12,000 kg

Engine

Power 140 kW @ 2,600 rpm

Torque 513 Nm @ 1,600 - 2,600 rpm

Transmission

6 speed manual transmission (MT)

6 speed automated manual transmission (AM)

Wheelbase

3,365 mm

3,815 mm

4,475 mm

Key Features

- ADR 80/04 (Euro VI) Compliant
- Advanced Emergency Braking (AEB)
- Automatic Lighting System (ALS)
- Bi-LED Headlamps with Daytime Running Lamps
- ECE-R29 cab with side anti-intrusion beams
- Electronic Stability Control (ESC)
- Lane Departure Warning (LDW)
- Full Speed Adaptive Cruise Control (FACC)**

** Automated manual transmission only



Truck Finder

Scan to search, view and download full spec sheets for all Isuzu truck models.

ISUZU
TRUCKS

Driveline

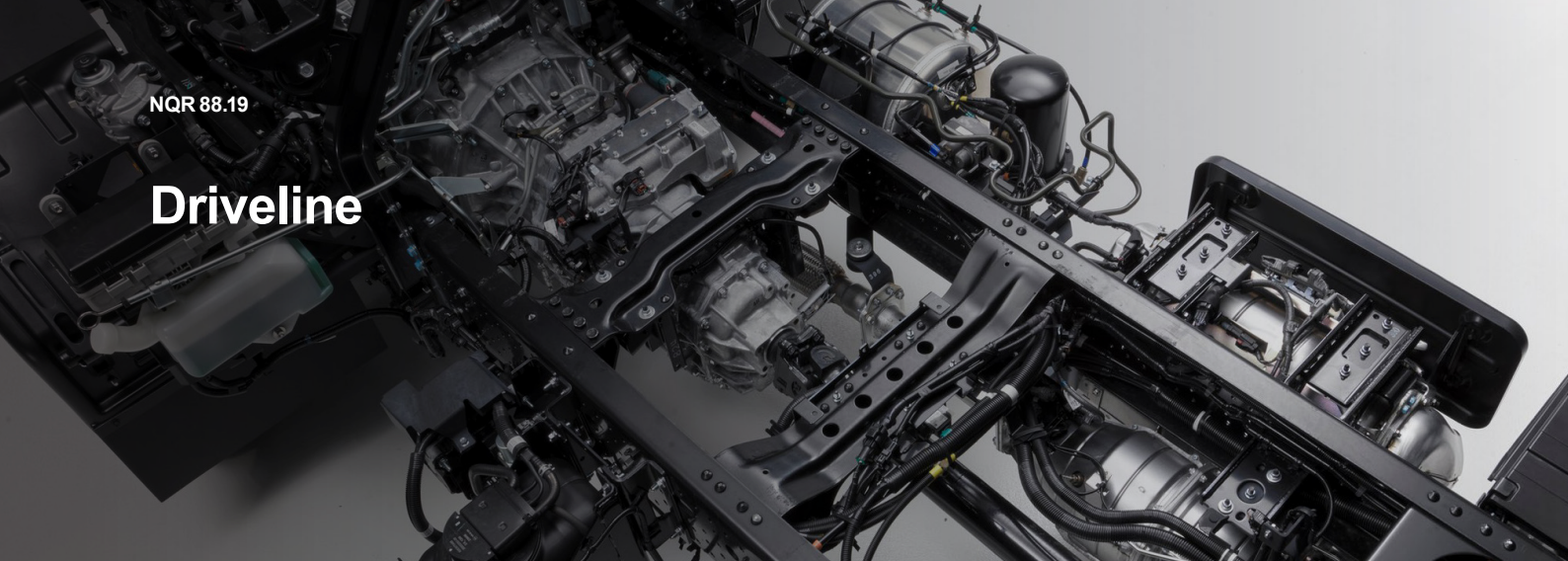

Engine

Description	Isuzu 4HK1-TCC
Type	4 cylinder
Power	140 kW (190PS) @ 2,600 rpm
Torque	513 Nm @ 1,600 - 2,600 rpm
Displacement	5,193 cc
Bore x Stroke	115 mm x 125 mm
Induction	Electronically controlled variable nozzle turbocharger with air-to air intercooler.
Fuel Injection	Direct injection high pressure common rail system
Emission Standard	ADR 80/04 (EuroVI-C) compliant
Emission Control	SCR (Selective Catalytic Reduction) DPD (Diesel Particulate Diffuser) EGR (Exhaust Gas Recirculation)
Auxiliary Brake	Vacuum controlled exhaust brake

4HK1-TCC 190PS Euro-VI

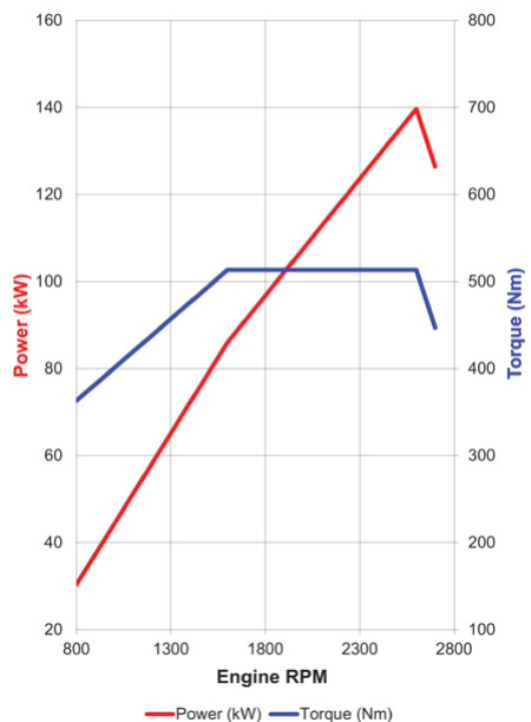

Transmission

	Description: ISUZU MZZ-6F							
	Type: 6 speed manual with synchromesh on gears 1 - 6							
MT	Ratios:							
	1	2	3	4	5	6	REV	
	6.36	3.76	1.96	1.35	1.00	0.78	6.36	
	Power Take Off Facility: Provision on LHS of transmission case. Drive from counter gear.							
	Description: ISUZU MZZ-6F							
	Type: 6-speed Automated Manual (AM) with both fully automatic and clutchless manual operation modes							
AM	Ratios:							
	1	2	3	4	5	6	REV	
	6.36	3.76	1.96	1.35	1.00	0.78	6.36	
	Power Take Off Facility: Provision on LHS of transmission case. Driven from counter gear.							

Clutch

	Type: Single plate with auto adjusting hydraulic control and vacuum assistance
MT	
	Clutch Plate Diameter: 325 mm
AM	Type: Fully automated electro/hydraulically controlled wet clutch and fluid coupling with lock up

Technology & Equipment

Intelligent Safety

ACTIVE SAFETY	Advanced Emergency Braking (AEB)
	Anti Lock Braking System (ABS)
	Anti Skid Regulator (ASR)
	Attention Alert System (AAS)
	Auto Lighting System (ALS)
	Distance Warning System (DWS)
	Electronic Stability Control (ESC)
	Electronic Park Brake (EPB)
	Electronic Brakeforce Distribution (EBD)
	Front Cross Traffic Alert (FCTA)
	Full Speed Adaptive Cruise Control (FACC)**
	Intelligent Speed Limiter (ISL)
	Intersection Emergency Braking (IEB)
	Intersection Warning System (IWS)
	Lane Departure Warning (LDW)
	Miss Acceleration Mitigation (MAM)**
	Traffic Movement Warning (TMW)
Traffic Sign Recognition (TSR)**	
PASSIVE SAFETY	Driver and Front Left Hand Passenger Seatbelt Pretensioners
	Driver and Front Passenger Airbags
	ECE-R29 Cab with Side Anti-Intrusion Beams
	Door mounted cornering lamps

CABIN OCCUPANT SAFETY SYSTEMS (COSS)

** Automated manual transmission only

Accessories

	Isuzu Genuine Bull Bar	●
	Isuzu Seat Covers	●
	Isuzu Floor Mats	●
Protection	Isuzu Dash Mats	●
	Isuzu Mudflaps	●
	Isuzu Cameras	●
Technology	Air Deflectors	●
	Warning Triangles	●
Aerodynamics	Wheel Nut Indicators	●
	Signage	●

● Fitted as Standard ● Option to Fit

Some options are provided via 3rd party retailer. Please discuss with your local Isuzu dealer.

Cabin Features

General Features

Audible Warning	Reverse alarm
Engine Access	Access hatch under driver's seat and tiltable front passenger seat (Crew cab) Manual cab tilt to 45° with torsion bar assistance (Single cab)
Steps	Heavy duty anti slip steps
Mirrors	Heated and powered exterior main mirrors with flat glass and adjustable convex "spot" mirrors
Wipers	Two speed windscreen wipers with intermittent wipe mode
Exterior Lighting	BI-LED Headlamps with LED Daytime Running Lamps (DRL)
	LED tail lamps
	Front LED fog lamps
	Roof mounted clearance lamps
Front Bumper	3-piece resin, body coloured
Security	Remote central locking and immobiliser

Premium Isuzu Audio Visual Unit

Connectivity	Bluetooth
	USB socket
	WiFi with over-the-air updates
	Input for up to 6 High Definition (HD) cameras (available accessory)
Radio	AM / FM
Screen Type	8" High Definition with capacitive touch
Smartphone Integration*	Wireless Apple CarPlay®
	Wireless Android Auto™
	Wi-Fi connectivity
Navigation	Provided via smartphone application

CarPlay is a trademark of Apple Inc.
Android Auto is a trademark of Google LLC.



Cabin Interior

Air Conditioning	Manual climate control
Door Windows	Electric control
Entry Assist Grips	Door and roof pillar mounted
Interior Lighting	LED lamp
Power Outlet	24V cigarette lighter
Seatbelts	3-point lap sash seatbelts in all outboard seating positions. Centre seat lap belts.
Seating	Driver's bucket seat equipped with mechanical suspension and weight adjustment to 130kg (Single cab)
	Driver's bucket seat (Crew cab)
	Passenger benchseat with 2 seat capacity Rear bench seat with 4 seat capacity (Crew cab)
Steering Column	Tilt / telescopic adjustable
Storage	Overhead cabinet, two cup holders, door pockets

Driver Control

	Full speed adaptive cruise control**
Engine	DPD manual regeneration switch
	Idle speed control
General Controls	Windscreen wipers (2 speed and intermittent modes), washers, exhaust brake, turn signals
Safety Systems	AEB on/off, DWS on/off/sensitivity adjust, LDW on/off/sensitivity adjust, TMW on/off, ESC&ASR on off, headlamps and ALS on/off.
Steering Wheel Controls	Multi Information Display controls
	Audio Visual volume control
	Audio Visual seek controls
	Phone control ADAS controls
Transmission	Gear selection control with R-N-D and sequential shift positions

** Automated manual transmission only

Instrumentation

	Digital odometer with integrated dual tripmeters
General Instrumentation	Engine coolant temperature and fuel level gauges
	Speedometer and tachometer
	Adjustable vehicle speed warning
Multi Information Display	AEB, FCW, DWS, LDW, TMW systems activation alerts
	CTW indicator
	Hourmeter
	Vehicle systems status

Chassis

Steering

Type	Power assisted recirculation ball
Turns Lock To Lock	5.40
Lock Angle Inside	42.5 °
Lock Angle Outside	32.7 °

Suspension

Front	Type: Single stage steel taper leaf spring.
	Other Features: Double acting hydraulic shock absorbers.
Rear	Type: Multi leaf main spring, taper leaf helper spring.
	Other Features: Double acting hydraulic shock absorbers. Stabiliser bar.

Fuel Tank

Diesel Tank	Type: Frame mounted steel tank
	Maximum capacity²: 140 L
	Fuel cap: Lockable cap
AdBlue[®] Tank	Type: Frame mounted high-density polyethylene tank
	Maximum capacity²: 16 L

Electrical Systems

Type	24 volt
Alternator	90 amp
Battery	MT 2 x 80D26L (600 CCA) batteries connected in series
	AM 2 x 115E41L (651 CCA) batteries connected in series
CAN Bus provision	FMS Provision

Chassis Frame

Type	Cold rivetted ladder frame
Material	HT540 steel
Dimensions	Side rail (mm): 70 x 230 x 5.0 Rear frame width (mm): 850

Axles

Front	Description: Isuzu F031
	Type: Reverse Elliot I-beam
	Capacity: 3,100 kg
Rear	Description: Isuzu R066
	Type: Full floating banjo with four differential pinions
	Capacity: 6,600 kg
	Ratio: 4.300 (MT), 4.556 (AM)

Wheels & Tyres

Front	Wheels: 19.5 x 6.0 six stud steel wheels
	Tyres: 225/70R19.5
	Steer axle tyre rating: 3,300 kg
Rear	Wheels: 19.5 x 6.0 six stud steel wheels
	Tyres: 255/70R19.5
	Rear axle tyre rating: 6,200 kg
Spare	Wheel: 19.5 x 6.0 six stud steel wheel
	Tyre: 225/70R19.5

Brakes

Type	Ventilated disc/disc with dual circuit hydraulic control, and integrated boost assist
Diameter Front	363 mm
Diameter Rear	348 mm
Park Brake	Electronic Park Brake (EPB) drum mounted on rear of transmission.

Weights & Dimensions

Weights (kg)

Models	Ratings ³		Loading Limit ³ (at ground)		Cab Chassis Weight ⁴			Model Code
	GVM	GCM	Front	Rear	Front	Rear	Total	
NQR 88.19 MT D34	8,800	12,000	3,100	6,200	1,928	1,059	2,987	NQ2601
NQR 88.19 AM D34	8,800	12,000	3,100	6,200	1,953	1,069	3,022	NQ2602
NQR 88.19 MT D38	8,800	12,000	3,100	6,200	1,980	1,029	3,009	NQ2603
NQR 88.19 AM D38	8,800	12,000	3,100	6,200	2,005	1,039	3,044	NQ2604
NQR 88.19 MT D45	8,800	12,000	3,100	6,200	2,045	1,004	3,049	NQ2605
NQR 88.19 AM D45	8,800	12,000	3,100	6,200	2,070	1,014	3,084	NQ2606
NQR 88.19 MT C45	8,800	12,000	3,100	6,200	2,238	1,107	3,345	NQ2607
NQR 88.19 AM C45	8,800	12,000	3,100	6,200	2,263	1,117	3,380	NQ2608

Dimensions (mm)

Models	WB	OAL	FOH	ROH	CA	RT	ORT	CH	FFH (Unladen)	RFH (Unladen)	EFH (Unladen)	Turning Circle Kerb to Kerb (m) ⁵
NQR 88.19 MT/AM D34	3,365	5,985	1,110	1,510	2,792	1,670	2,155	2,278	719	819	864	12.46
NQR 88.19 MT/AM D38	3,815	6,635	1,110	1,710	3,242	1,670	2,155	2,276	717	819	865	14.12
NQR 88.19 MT/AM D45	4,475	7,815	1,110	2,230	3,902	1,670	2,155	2,274	715	820	872	16.57
NQR 88.19 MT/AM C45	4,475	7,815	1,110	2,230	2,911	1,670	2,155	2,274	715	818	869	16.57

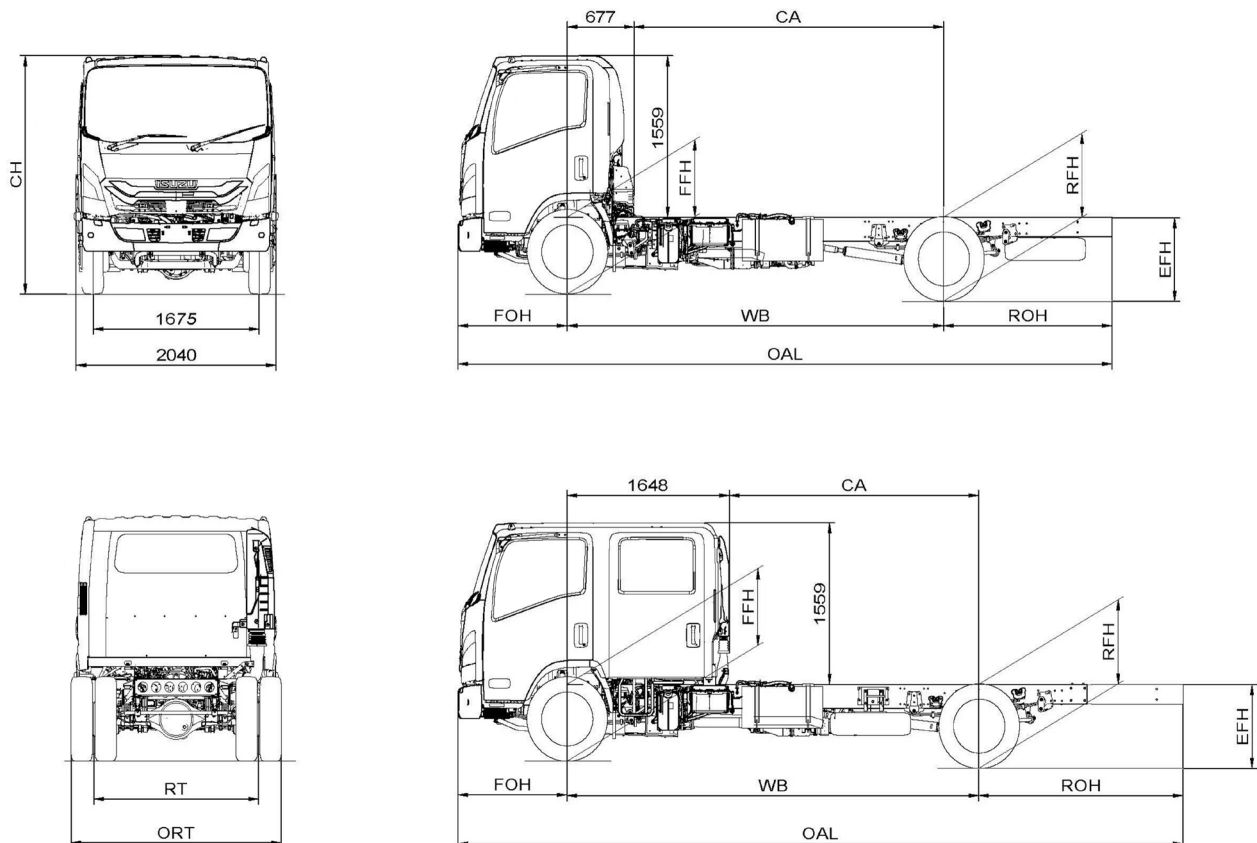

Drawing for reference only. Refer to the Isuzu Body Builder Guide for details.

Service & Support



Dealer Network

Service & Support	National Isuzu Truck Dealer Network and Accredited Service Centres
	Find a Dealer Online

Warranty#

Chassis	5 Year Warranty# 250,000 km#
Genuine Parts & Accessories	2 Year Warranty or 50,000km# (When installed by an Isuzu Trucks Approved Dealership - Including Labor)

Find your local dealer
Scan QR Code



Total 5 Year Warranty, including Base Warranty (36 months / 100,000kms) and Additional Warranty (24 months / 150,000kms), cover is 60 months or 250,000kms, whichever comes first. To qualify for Additional Warranty, all scheduled servicing during the Base and Additional Warranty periods (ie. the total 60 months) must be performed by an authorised Isuzu service dealer from the date of delivery to the first customer. If scheduled servicing is performed by unauthorized service providers, only the Base Warranty will apply. Tipper bodies are excluded from Additional Warranty. These are covered by Base Warranty only.

² As shown on fuel tank. Volume of fuel that can be added to a near-empty tank will vary according to operating conditions.

³ Vehicle ratings and axle weight limits are subject to government regulatory requirements and weight distribution analysis. Consult your Isuzu dealer to select the correct vehicle for your specific application.

⁴ Cab chassis only as supplied including 90% fuel and tools/spare wheel (if applicable).

⁵ Turning circle dimensions are based on manufacturers calculations and may vary under real-world conditions.

The information in this spec sheet was correct at time of printing, but all measurements, specifications and equipment are subject to change without notice. Some equipment may have been changed and/or is available at extra cost. Isuzu New Zealand (INZ) may make changes at any time without notice, in prices, colours, materials, equipment and models. INZ makes all reasonable attempts to ensure the availability of all vehicles and equipment. The information in this spec sheet is general in nature. Your Isuzu dealer can confirm all measurements, specifications and vehicle / equipment availability upon request. To the extent permitted by the law, INZ is not liable to any person as result of reliance on the content of this spec sheet.

^Advance Driver Assistance Systems are intended to support the driver but are not a replacement for safe driving practices.

*Smartphone Integration compatible with selected apps and the latest smartphone versions of iOS and Android.Active data service is required for some functionality. For USB connections, a connection cable is sold separately.

