

FYJ 350S AUTO 8X4



WEIGHT RATINGS*

GVM	30,000 kg
GCM	42,500 kg

ENGINE

POWER	257 kW @ 2,000 rpm
TORQUE	1,422 Nm @ 1,400 rpm

TRANSMISSION

6 speed automatic transmission (AT)

* Refer to back page for detailed weight rating information

ENGINE	
DESCRIPTION	Isuzu 6UZ1-TCN
TYPE	6 cylinder 24 valve SOHC
DISPLACEMENT	9,839 cc
COMPRESSION RATIO	17.5:1
BORE X STROKE	120 mm x 145 mm
POWER	257 kW (350PS) @ 2,000 rpm (DIN NET)
TORQUE	1,422 Nm @ 1,400 rpm (DIN NET)
INDUCTION	Electronically controlled variable nozzle turbocharger with air-to-air intercooler
FUEL INJECTION	Direct injection high pressure common rail
EMISSION CONTROL	Cooled EGR with exhaust Diesel Oxidation Catalyst (DOC). ADR 80/03 (Euro V) compliant.

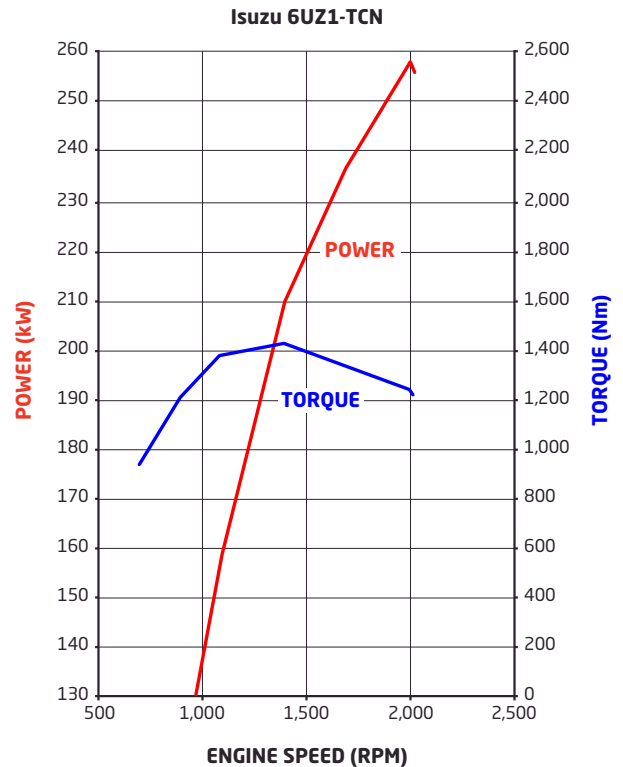

INTELLIGENT SAFETY		
ACTIVE SAFETY	Anti-Lock Braking System	(ABS)
	Electronic Stability Control (ESC)	(ESC)
	Driver airbag	
	Driver seatbelt pretensioner	

ISUZU WARRANTY COVER

HARSH APPLICATION WARRANTY (CONCRETE AGITATOR / GARBAGE COMPACTOR)	3 year / 200,000 km Warranty#
---	-------------------------------

TRANSMISSION							
AT	Description: Allison 4430						
	Type: 6 speed automatic						
	Ratios:						
	1st	2nd	3rd	4th	5th	6th	Rev
	4.70	2.21	1.53	1.00	0.76	0.67	5.55
Power Take Off facility: LHS and top openings on transmission bellhousing. Engine driven PTO drive gear.							
Other features: 5th generation electronic controls with adaptive shift. Long life TranSynd synthetic fluid.							

WHEELS & TYRES		
FRONT	WHEELS	22.5 x 7.50 ten stud ISO standard polished Alcoa aluminium wheels
	TYRES	11R22.5 148/145L Dunlop SP160 Tubeless
	STEER AXLE TYRE RATING	12,600 kg
REAR	WHEELS	22.5 x 7.50 ten stud ISO standard polished Alcoa aluminium wheels
	TYRES	11R22.5 148/145L Dunlop SP431A Tubeless
	TANDEM AXLE TYRE RATING	23,200 kg

AXLES	
FRONT	Description: 2 x Meritor FG941
	Type: Reverse Elliot I-beam
	Capacity: 6,600 kg each
REAR	Description: Meritor MT-14X
	Type: Tandem drive
	Other features: Inter-axle lock and cross locks fitted to both axles
	Capacity: 18,100 kg
	Ratio: 5.286:1

CHASSIS FRAME	
TYPE	Cold rivetted ladder frame.
MATERIAL	HT540A steel members
DIMENSIONS	Side rail (mm): 285 x 85 x 7.0 Rear frame width (mm): 850

SUSPENSION	
FRONT	Type: Single stage alloy steel taper leaf springs
	Load sharing: Front suspension load equaliser and shock absorber
	Other features: Double acting hydraulic shock absorbers fitted to both axles. Stabiliser bar fitted to first front axle.
REAR	Description: Hendrickson HAS461
	Type: Airbag
	Capacity: 20,865 kg at ground

FUEL TANK	
TYPE	Frame mounted aluminium fuel tank
CAPACITY	200 L
FUEL CAP	Lockable

ELECTRICAL SYSTEM	
TYPE	24 volt
ALTERNATOR	90 amp
STARTER MOTOR	5.0 kW
BATTERY	2 x 115E41L (651 CCA) batteries connected in series
CAN BUS PROVISION	Underdash CAN system access plug for connection to a Fleet Management System (FMS) (not supplied)

BRAKES	
DESCRIPTION	Meritor 'Q-Plus'
TYPE	Full air 'S-Cam' front and rear drum brakes
DIAMETER X WIDTH FRONT	419 x 152 mm
DIAMETER X WIDTH REAR	419 x 178 mm
PARK BRAKE	Spring park brake acting on all rear wheels
AUXILIARY BRAKE	Air controlled exhaust brake

STEERING	
TYPE	Power assisted recirculating ball
GEAR RATIO	1st axle: 18.8:1
	2nd axle: 22.9:1
TURNS LOCK TO LOCK	3.8
WHEEL LOCK ANGLE	1st axle: 40.0° (inside wheel) / 32.2° (outside wheel)
	2nd axle: 34.0° (inside wheel) / 28.6° (outside wheel)

CABIN GENERAL FEATURES	
ENGINE ACCESS	Electro-hydraulic cab tilt
CAB MOUNTING	Rear coil spring suspension with hydraulic shock absorbers
STEPS	Heavy duty anti-slip steps
DOORS	90° opening internally reinforced front doors
MIRRORS	Heated and powered exterior main mirrors with flat glass and additional independently adjustable convex "spot" mirrors
WIPERS	Two speed windscreen wipers with intermittent wipe mode
EXTERIOR LIGHTING	LED main beam and halogen high beam headlamps. Chrome surround.
	Roof mounted clearance lamps
	Front foglamps
AUDIBLE WARNING	Reverse alarm
GRILLE	Chrome
FRONT BUMPER	Body coloured air dam type
SECURITY	Central locking with remote keyless entry and immobiliser

CABIN INTERIOR	
SEATING	Isri 6860/875 NTS air suspension driver's seat
	Front passenger adjustable bucket seat and front centre seat with folding seat back
SEATBELTS	3-point lap sash seatbelts in all outboard seating positions. Driver seatbelt integrated with driver seat. Centre seat lap belts.
STEERING COLUMN	Tilt/telescopic adjustable
ENTRY ASSIST GRIPS	Door and roof pillar mounted
DOOR WINDOWS	Electric control
STORAGE	Overhead compartments
	Twin cup holders
	Centre console box and storage tray
	Passenger glovebox
	Door pockets
POWER OUTLET	24V cigarette lighter
	2.4A high current fast charge USB socket
AIRCONDITIONING	Auto control
INTERIOR LIGHTING	Fluorescent lamp
REAR COMPARTMENT	ADR 42 compliant sleeper with mattress

AUDIO VISUAL UNIT	
SCREEN TYPE	6.2" LCD with capacitive touch
OPERATING SYSTEM	Android
RADIO	AM / FM
INTERNAL STORAGE CAPACITY	32GB
OTHER CAPABILITY	Bluetooth features. USB 3.0 socket. Provision for external camera inputs, navigation, reverse sensors, and tyre pressure monitoring.

DRIVER CONTROLS	
ENGINE	Idle speed control
TRANSMISSION	Push button gear selection control
GENERAL CONTROLS	Headlamp on/off and levelling, windscreen wipers (2 speed and intermittent modes), washers, exhaust brake, turn signals
	Inter-axle lock and cross lock engage switches

INSTRUMENTATION	
MULTI INFORMATION DISPLAY	Vehicle systems status
	Low fuel level alert
	Fuel consumption information
	Service interval alerts
	Hourmeter
GENERAL INSTRUMENTATION	Adjustable vehicle speed warning
	Speedometer and tachometer
	Digital odometer with integrated dual tripmeters
	Transmission oil level, oil life, filter life, and condition monitor display
	Engine coolant temperature, fuel level and air pressure gauges

WEIGHTS (kg)							
MODELS	RATINGS*		LOADING LIMIT* (at ground)		CAB CHASSIS WEIGHT #		
	GVM	GCM	FRONT	REAR	FRONT	REAR	TOTAL
FYJ 350S AUTO	30,000	42,500	12,000	18,100	5,835	2,185	8,020

* Vehicle ratings and front/rear weight limits are subject to government regulatory requirements and weight distribution analysis. Consult your Isuzu dealer to select the correct vehicle for your specific application. # Cab chassis only as supplied and including 10 litres of fuel.

DIMENSIONS (mm)													(m)
MODELS	WB	OAL	FOH	ROH	EA	CE	RT	ORT	CH	FFA (unladen)	RFA (unladen)	RFH (unladen)	TURNING CIRCLE kerb to kerb
FYJ 350S AUTO	5,080	9,030	1,480	2,470	3,870	6,880	1,860	2,445	3,000	925	1,040	1,040	17.9

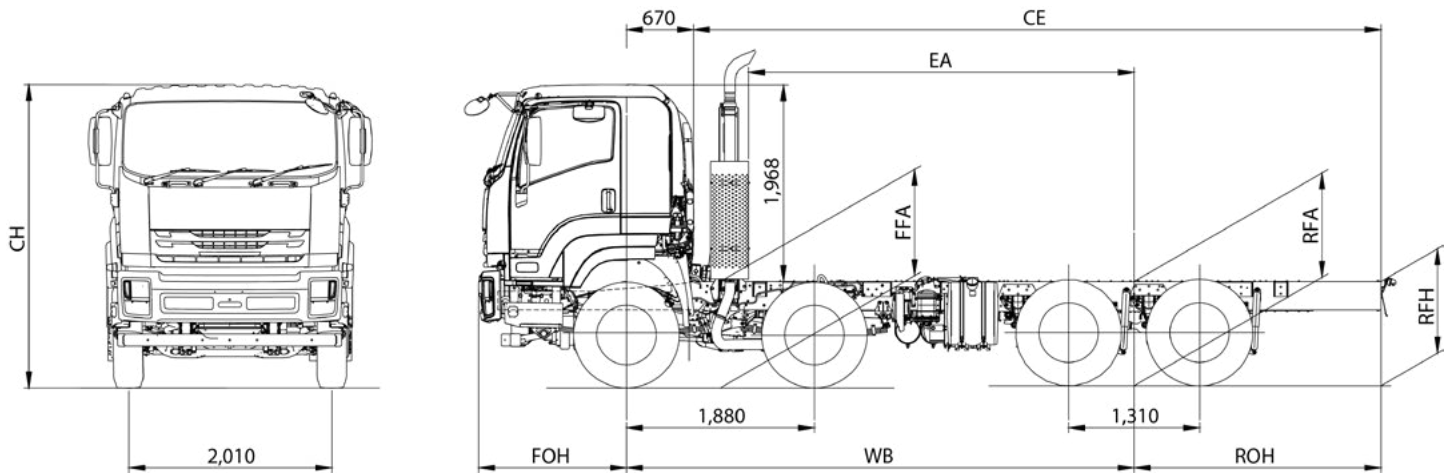

PERFORMANCE (calculated - typical paved road)				
		GEARED SPEED [^] (top gear at peak power engine rpm)	LOW SPEED GRADEABILITY (lowest forward gear assuming no wheel slip)	ENGINE SPEED (top gear at 90 km/h)
FYJ 350S AUTO	At 30,000 kg GVM	109 km/h @ 2,000 rpm	48%	1,647 rpm

[^] Maximum speed achievable depends on vehicle frontal area as well as other factors. Consult your Isuzu dealer for more detailed information. Vehicle is speed limited to 100km/h.

ORDER CODES	
MODELS	CODES
FYJ 350S AUTO	FY0621

3 Year Warranty (36 months / 200,000kms) cover is 36 months or 200,000kms, whichever comes first. Cab Perforation Corrosion is limited to 36 months / unlimited kms on all models. The information in this spec sheet was correct at time of printing, but all measurements, specifications and equipment are subject to change without notice. Some equipment may have been changed and/or is available at extra cost. Isuzu New Zealand (INZ) may make changes at any time without notice, in prices, colours, materials, equipment and models. INZ makes all reasonable attempts to ensure the availability of all vehicles and equipment. The information in this spec sheet is general in nature. Your Isuzu dealer can confirm all measurements, specifications and vehicle / equipment availability upon request. To the extent permitted by the law, INZ is not liable to any person as result of reliance on the content of this spec sheet.