

NPR 450 TIPPER NPR 450/NPR 425 CREW TIPPER



WEIGHT RATINGS

GVM	7,500 kg / 5,995 kg*
GCM	11,000 kg

*CREW CAB model only

ENGINE

POWER	140 kW @ 2,600 rpm
TORQUE	513 Nm @ 1,600 - 2,600 rpm

TRANSMISSION

6 speed manual transmission (MT)
6 speed automated manual transmission (AMT)

* Refer to back page for detailed weight rating information

INTELLIGENT SAFETY		
ACTIVE SAFETY ADVANCED DRIVER ASSISTANCE SYSTEMS (ADAS)	Advanced Emergency Braking	(AEB)
	Forward Collision Warning	(FCW)
	Distance Warning System	(DWS)
	Lane Departure Warning	(LDW)
	Traffic Movement Warning	(TMW)
	Electronic Stability Control	(ESC)
	Anti-Skid Regulator	(ASR)
	Anti-Lock Braking System	(ABS)
	Customisable Speed Limiter	(CSL)
	Hill Start Aid (MT only)	(HSA)
PASSIVE SAFETY CABIN OCCUPANT SAFETY SYSTEMS (COSS)	Automatic Lighting System (Front & Rear)	(ALS)
	Cab Tilt Warning (single cab only)	(CTW)
	Driver & front passenger airbags	
	Driver & front left hand passenger seatbelt pretensioners	
	ECE-R29 cab with side anti-intrusion beams	
Handsfree functions on steering wheel		
Door mounted cornering lamps		

READY TO WORK	
STANDARD FEATURES	All steel body with drop sides
	Auto release two-way tailgate
	Auto release body lockdown hook
	Shovel rack
	LHS and RHS rope rails
	Non-slip side steps
	20 sec. raise / 20 sec. lower time
	Cubic volume: 3.0 m ³ (single cab), 2.8 m ³ (crew cab)
	Deck plate thickness: 3.2 mm
	Side / front / tail plate thickness: 2.3 mm

ISUZU WARRANTY COVER	
WARRANTY	5 Year / 250,00 km Warranty#
ENGINE	
DESCRIPTION	Isuzu 4HK1-TCC
TYPE	4 cylinder 16 valve SOHC
DISPLACEMENT	5,193 cc
COMPRESSION RATIO	17.5:1
BORE X STROKE	115 mm x 125 mm
POWER	140 kW (190PS) @ 2,600 rpm (DIN NET)
TORQUE	513 Nm @ 1,600 - 2,600 rpm (DIN NET)
INDUCTION	Electronically controlled variable nozzle turbocharger with air-to-air intercooler
FUEL INJECTION	Direct injection high pressure common rail
EMISSION CONTROL	Cooled EGR with exhaust Diesel Oxidation Catalyst (DOC). ADR 80/03 (Euro V / EEV) compliant.

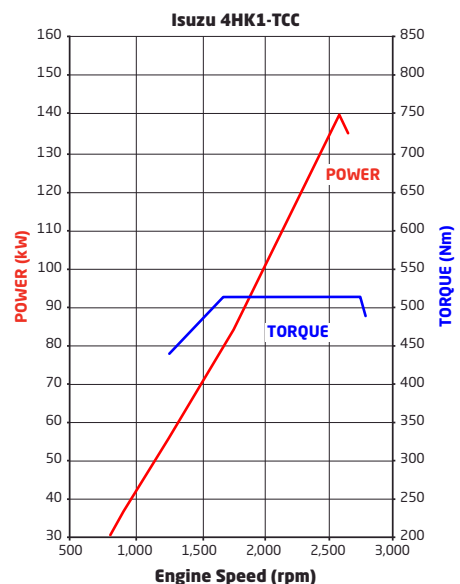

NPR 450 TIPPER

NPR 450/NPR 425 CREW TIPPER

CLUTCH	
MT	Type: Single plate with auto adjusting hydraulic control and vacuum assistance
	Clutch Plate Diameter: 325 mm
	Clutch lining area: 966 cm ²
AMT	Type: Fully automated electro/hydraulically controlled wet clutch and fluid coupling with lock up

TRANSMISSION															
MT	Description: Isuzu MZZ-6F														
	Type: 6 speed manual. Syncromesh on gears 1-6.														
	Ratios: <table border="1"> <thead> <tr> <th>1ST</th> <th>2ND</th> <th>3RD</th> <th>4TH</th> <th>5TH</th> <th>6TH</th> <th>REV</th> </tr> </thead> <tbody> <tr> <td>6.369</td> <td>3.767</td> <td>1.966</td> <td>1.355</td> <td>1.000</td> <td>0.782</td> <td>6.369</td> </tr> </tbody> </table>	1ST	2ND	3RD	4TH	5TH	6TH	REV	6.369	3.767	1.966	1.355	1.000	0.782	6.369
1ST	2ND	3RD	4TH	5TH	6TH	REV									
6.369	3.767	1.966	1.355	1.000	0.782	6.369									
AMT	Description: Isuzu MZZ-6F														
	Type: 6 speed with both fully automatic and clutchless manual operation modes														
	Ratios: <table border="1"> <thead> <tr> <th>1ST</th> <th>2ND</th> <th>3RD</th> <th>4TH</th> <th>5TH</th> <th>6TH</th> <th>REV</th> </tr> </thead> <tbody> <tr> <td>6.369</td> <td>3.767</td> <td>1.966</td> <td>1.355</td> <td>1.000</td> <td>0.782</td> <td>6.369</td> </tr> </tbody> </table>	1ST	2ND	3RD	4TH	5TH	6TH	REV	6.369	3.767	1.966	1.355	1.000	0.782	6.369
	1ST	2ND	3RD	4TH	5TH	6TH	REV								
6.369	3.767	1.966	1.355	1.000	0.782	6.369									
Power Take Off facility: Provision on LHS of transmission case. Drive from counter gear.															

AXLES	
FRONT	Description: Isuzu F031
	Type: Reverse Elliot I-beam
	Capacity: 3,100 kg
REAR	Description: Isuzu R066
	Type: Full floating banjo with four differential pinions
	Capacity: 6,600 kg
	Ratio: 3.909 (MT) 4.100 (AMT)

SUSPENSION	
FRONT	Single cab: Single stage alloy steel taper leaf springs Crew cab: Single stage alloy steel multi leaf springs
	Double acting hydraulic shock absorbers. Stabiliser bar.
REAR	Multi leaf main, taper leaf helper spring
	Double acting hydraulic shock absorbers. Stabiliser bar.

BRAKES	
TYPE	Ventilated disc/disc with dual circuit hydraulic control, vacuum assistance and electronic brake force distribution (EBD)
DIAMETER FRONT	310 mm
DIAMETER REAR	310 mm
PARK BRAKE	203 mm diameter drum mounted on rear of transmission
AUXILIARY BRAKE	Vacuum controlled exhaust brake

STEERING	
TYPE	Power assisted recirculating ball
GEAR RATIO	20.9
TURNS LOCK TO LOCK	5.4
WHEEL LOCK ANGLE	43° (inside wheel) / 33° (outside wheel)

WHEELS & TYRES	
FRONT	Wheels: 17.5 x 6.00 six stud steel
	Tyres: 215/75R 17.5 126/124M Bridgestone Tubeless
	Steer axle tyre rating: 3,400 kg
REAR	Wheels: 17.5 x 6.00 six stud steel
	Tyres: 215/75R 17.5 126/124M Bridgestone Tubeless
	Drive axle tyre rating: 6,400 kg
SPARE	1 frame mounted spare wheel and tyre assembly

CHASSIS FRAME	
TYPE	Cold rivetted ladder frame. SAPH440 steel sidemembers. Parallel side rails and rivetless top flange.
DIMENSIONS	Side rail (mm): 216 x 70 x 6.0 Rear frame width (mm): 850

FUEL TANK	
TYPE	Frame mounted steel fuel tank
CAPACITY	140L
FUEL CAP	Lockable

ELECTRICAL SYSTEM	
TYPE	24 volt
ALTERNATOR	90 amp
STARTER MOTOR	4.0 kW
BATTERY	2 x 80D26L (630 CCA) batteries connected in series

CABIN GENERAL FEATURES	
ENGINE ACCESS	Single cab: manual cab tilt to 45° with torsion bar assistance Crew cab: access hatch under driver's seat and tiltable front passenger seat
STEPS	Heavy duty anti-slip steps
DOORS	90° opening internally reinforced front doors
MIRRORS	Cab mounted convex mirrors with left side under view mirror
WIPERS	Two speed windscreen wipers with intermittent wipe mode
EXTERIOR LIGHTING	Multi-reflector halogen headlamps
AUDIBLE WARNING	Reverse alarm
GRILLE	Cabin coloured
SECURITY	Central locking with remote keyless entry and immobiliser

CABIN INTERIOR	
SEATING	Single cab: driver's bucket seat equipped with mechanical suspension and weight adjustment to 130 kg Crew cab: driver's bucket seat Front passenger bench seat with 2 seat capacity Crew cab: rear bench seat with 4 seat capacity
SEATBELTS	3-point lap sash seatbelts in all outboard seating positions. Centre seat lap belts.
STEERING COLUMN	Tilt / telescopic adjustable
ENTRY ASSIST GRIPS	Door and roof pillar mounted Crew cab: full width rear grab rail
DOOR WINDOWS	Electric control
STORAGE	Overhead shelf Twin cup holders Front centre console box and storage tray Front door pockets
POWER OUTLET	24V cigarette lighter
AIRCONDITIONING	Manual control
INTERIOR LIGHTING	Single cab: fluorescent lamp Crew cab: standard lamp

DRIVER CONTROLS	
SAFETY SYSTEMS	AEB on/off, DWS on/off/sensitivity adjust, LDW on/off/sensitivity adjust, TMW on/off, ESC&ASR on/off, headlamps and ALS on/off, HSA on/off/sensitivity adjust
ENGINE	Idle speed control Cruise control
TRANSMISSION (AMT ONLY)	Slow/fast gear engagement control, 1st gear start and normal/economy gear selection modes Gear selection control with R-N-D and sequential shift positions
GENERAL CONTROLS	Windscreen wipers (2 speed and intermittent modes), washers, exhaust brake, turn signals Tip body raise and lower lever with safety release mechanism

AUDIO VISUAL UNIT	
SCREEN TYPE	6.2" LCD with capacitive touch
OPERATING SYSTEM	Android
RADIO	AM / FM
INTERNAL STORAGE CAPACITY	32GB
OTHER CAPABILITY	Provision for external camera inputs, navigation, reverse sensors and tyre pressure monitoring

INSTRUMENTATION	
MULTI INFORMATION DISPLAY	AEB, FCW, DWS, LDW, TMW systems activation alerts
	Single cab: CTW indicator
	Low engine oil level alert (activated when oil pan < 71% capacity)
	Vehicle systems status
	Low fuel level alert
	Fuel consumption information
	Service interval alerts
	Hourmeter
	Adjustable vehicle speed warning
	PTO engaged indicator
GENERAL INSTRUMENTATION	Speedometer and tachometer
	Digital odometer with integrated dual tripmeters
	Engine coolant temperature and fuel level gauges



AMT model shown

NPR 450 TIPPER NPR 450/NPR 425 CREW TIPPER

ISUZU TRUCKS

WEIGHTS (kg)							
MODELS	RATINGS*		LOADING LIMIT* (at ground)		WEIGHT #		
	GVM	GCM	FRONT	REAR	FRONT	REAR	TOTAL
NPR 450 TIPPER	7,500	11,000	3,100	6,400	1,980	1,630	3,610
NPR 450 / 425 CREW TIPPER	7,500 / 5,995	11,000	3,100	6,400	2,137	1,782	3,919

* Vehicle ratings and axle weight limits are subject to government regulatory requirements and weight distribution analysis. Consult your Isuzu dealer to select the correct vehicle for your specific application.

Vehicle as supplied and including 10 litres of fuel.

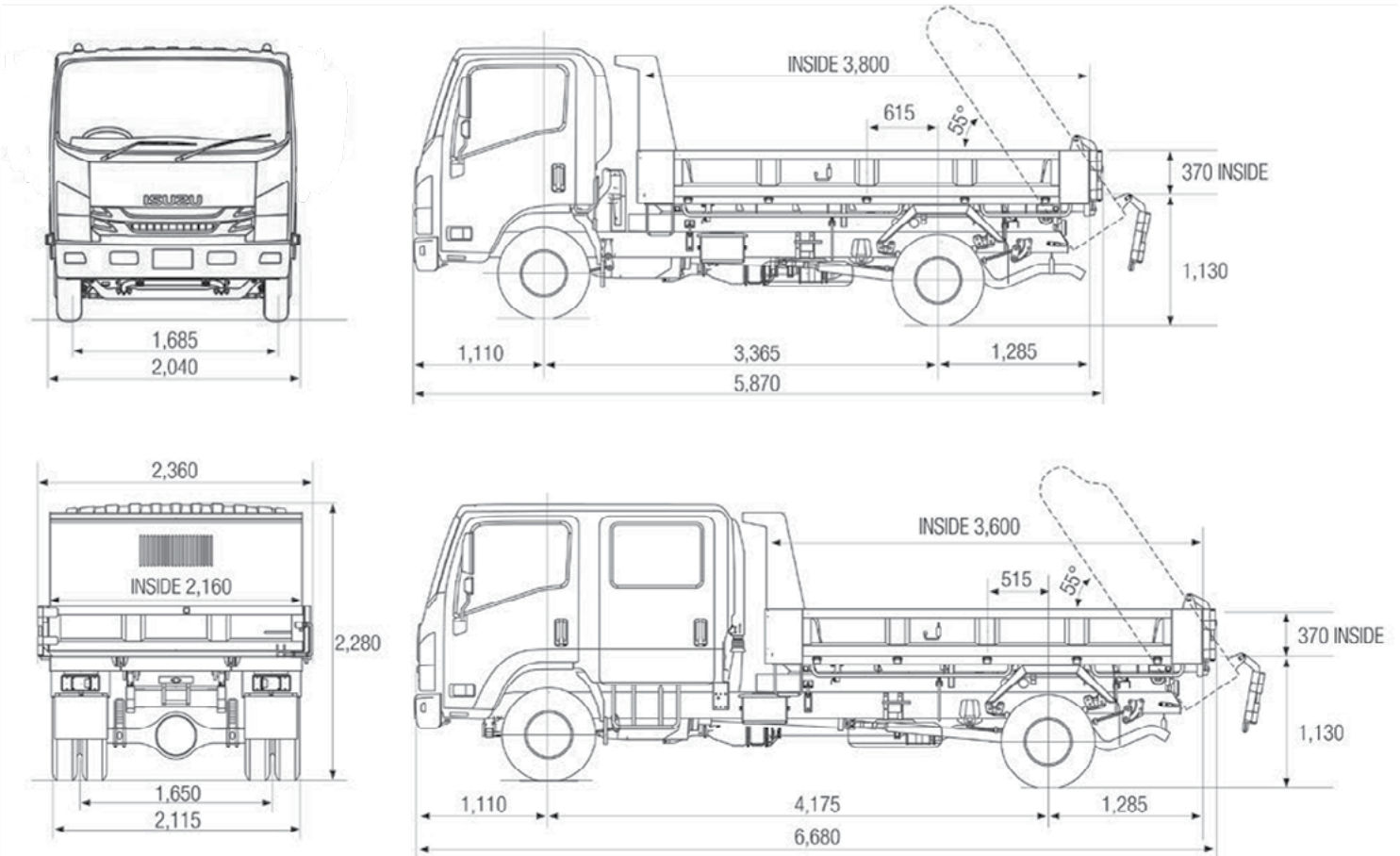

**TURNING CIRCLE
(kerb to kerb)**
Single: 12.4 m
Crew: 15.3 m

PERFORMANCE (calculated - typical paved road)				
MODELS	GVM	GEARED SPEED* (top gear at peak power engine rpm)	LOW SPEED GRADEABILITY (lowest forward gear assuming no wheel slip)	ENGINE SPEED (top gear at 90 km/h)
NPR 450 TIPPER	At 7,500 kg GVM	118 km/h @ 2,600 rpm	41%	1,937 rpm
NPR 450 AMT TIPPER	At 7,500 kg GVM	118 km/h @ 2,600 rpm	43%	2,032 rpm

* Maximum speed achievable depends on vehicle frontal area as well as other factors. Consult your Isuzu dealer for more detailed information.

ORDER CODES	
MODELS	CODES
NPR 450 TIPPER	NP3018
NPR 450 AMT TIPPER	NP3118
NPR 450 CREW TIPPER	NP3418
NPR 450 CREW AMT TIPPER	NP3518
NPR 425 CREW TIPPER	NP3618
NPR 425 CREW AMT TIPPER	NP3718

Total 5 Year Warranty, including Base Warranty (36 months / 100,000kms) and Additional Warranty (24 months / 150,000kms), cover is 60 months or 250,000kms, whichever comes first. To qualify for Additional Warranty, all scheduled servicing during the Base and Additional Warranty periods (ie. the total 60 months) must be performed by an authorised Isuzu service dealer from the date of delivery to the first customer. If scheduled servicing is performed by unauthorised service providers, only the Base Warranty will apply. For VL24 NPR Tipper models, additional Warranty applies to the cab & chassis only. Tipper bodies are excluded from Additional Warranty. These are covered by Base Warranty only. Cab Perforation Corrosion is limited to 36 months / unlimited kms on all models. It is not included as part of Additional Warranty.

The information in this spec sheet was correct at time of printing, but all measurements, specifications and equipment are subject to change without notice. Some equipment may have been changed and/or is available at extra cost. Isuzu New Zealand (INZ) may make changes at any time without notice, in prices, colours, materials, equipment and models. INZ makes all reasonable attempts to ensure the availability of all vehicles and equipment. The information in this spec sheet is general in nature. Your Isuzu dealer can confirm all measurements, specifications and vehicle / equipment availability upon request. To the extent permitted by the law, INZ is not liable to any person as result of reliance on the content of this spec sheet.