

## NPR 450 / NPR 425 NPR 450 CREW



### WEIGHT RATINGS

**GVM** 7,500 / 5,995 kg  
**GCM** \*SINGLE CAB only 11,000 kg

### ENGINE

**POWER** 140 kW @ 2,600 rpm  
**TORQUE** 513 Nm @ 1,600 - 2,600 rpm

### TRANSMISSION

6 speed manual transmission (MT)  
6 speed automated manual transmission (AMT)

\* Refer to back page for detailed weight rating information

INTELLIGENT SAFETY		
<b>ACTIVE SAFETY ADVANCED DRIVER ASSISTANCE SYSTEMS (ADAS)</b>	Advanced Emergency Braking	<b>(AEB)</b>
	Forward Collision Warning	<b>(FCW)</b>
	Distance Warning System	<b>(DWS)</b>
	Lane Departure Warning	<b>(LDW)</b>
	Traffic Movement Warning	<b>(TMW)</b>
	Electronic Stability Control	<b>(ESC)</b>
	Anti Skid Regulator	<b>(ASR)</b>
	Anti Lock Braking System	<b>(ABS)</b>
	Customisable Speed Limiter	<b>(CSL)</b>
	Hill Start Aid (MT only)	<b>(HSA)</b>
	Automatic Lighting System (Front and Rear)	<b>(ALS)</b>
Cab Tilt Warning (Single cab only)	<b>(CTW)</b>	
<b>PASSIVE SAFETY CABIN OCCUPANT SAFETY SYSTEMS (COSS)</b>	Driver and front passenger airbags	
	Driver and front left hand passenger seatbelt pretensioners	
	ECE-R29 cab with side anti-intrusion beams	
	Handsfree functions on steering wheel	
	Door mounted cornering lamps	

ISUZU WARRANTY COVER	
<b>WARRANTY</b>	5 Year / 250,00 km Warranty#

ENGINE	
<b>DESCRIPTION</b>	Isuzu 4HK1-TCC
<b>TYPE</b>	4 cylinder 16 valve SOHC
<b>DISPLACEMENT</b>	5,193 cc
<b>COMPRESSION RATIO</b>	17.5:1
<b>BORE X STROKE</b>	115 mm x 125 mm
<b>POWER</b>	140 kW (190PS) @ 2,600 rpm (DIN NET)
<b>TORQUE</b>	513 Nm @ 1,600 - 2,600 rpm (DIN NET)
<b>INDUCTION</b>	Electronically controlled variable nozzle turbocharger with air-to-air intercooler
<b>FUEL INJECTION</b>	Direct injection high pressure common rail
<b>EMISSION CONTROL</b>	Cooled EGR with exhaust Diesel Oxidation Catalyst (DOC). ADR 80/03 (Euro V) compliant.

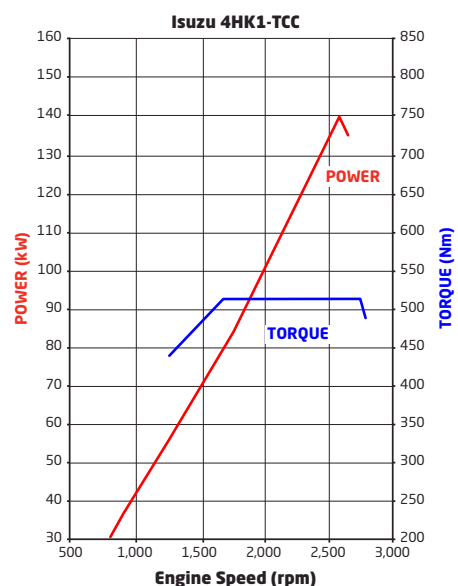

CLUTCH	
MT	<b>Type:</b> Single plate with auto adjusting hydraulic control and vacuum assistance
	<b>Clutch Plate Diameter:</b> 325 mm
	<b>Clutch lining area:</b> 966 cm <sup>2</sup>
AMT	<b>Type:</b> Fully automated electro/hydraulically controlled wet clutch and fluid coupling with lock up

TRANSMISSION														
MT	<b>Description:</b> Isuzu MZZ-6F													
	<b>Type:</b> 6 speed manual. Syncromesh on gears 1-6.													
	<b>Ratios:</b>													
	<table border="1"> <thead> <tr> <th>1ST</th> <th>2ND</th> <th>3RD</th> <th>4TH</th> <th>5TH</th> <th>6TH</th> <th>REV</th> </tr> </thead> <tbody> <tr> <td>6.369</td> <td>3.767</td> <td>1.966</td> <td>1.355</td> <td>1.000</td> <td>0.782</td> <td>6.369</td> </tr> </tbody> </table>	1ST	2ND	3RD	4TH	5TH	6TH	REV	6.369	3.767	1.966	1.355	1.000	0.782
1ST	2ND	3RD	4TH	5TH	6TH	REV								
6.369	3.767	1.966	1.355	1.000	0.782	6.369								
	<b>Power Take Off facility:</b> Provision on LHS of transmission case. Drive from counter gear.													
AMT	<b>Description:</b> Isuzu MZZ-6F													
	<b>Type:</b> 6 speed with both fully automatic and clutchless manual operation modes													
	<b>Ratios:</b>													
	<table border="1"> <thead> <tr> <th>1ST</th> <th>2ND</th> <th>3RD</th> <th>4TH</th> <th>5TH</th> <th>6TH</th> <th>REV</th> </tr> </thead> <tbody> <tr> <td>6.369</td> <td>3.767</td> <td>1.966</td> <td>1.355</td> <td>1.000</td> <td>0.782</td> <td>6.369</td> </tr> </tbody> </table>	1ST	2ND	3RD	4TH	5TH	6TH	REV	6.369	3.767	1.966	1.355	1.000	0.782
1ST	2ND	3RD	4TH	5TH	6TH	REV								
6.369	3.767	1.966	1.355	1.000	0.782	6.369								
	<b>Power Take Off facility:</b> Provision on LHS of transmission case. Drive from counter gear.													

AXLES	
FRONT	<b>Description:</b> Isuzu F031
	<b>Type:</b> Reverse Elliot I-beam
	<b>Capacity:</b> 3,100 kg
REAR	<b>Description:</b> Isuzu R066
	<b>Type:</b> Full floating banjo with four differential pinions
	<b>Capacity:</b> 6,600 kg
	<b>Ratio:</b> 3.909 (MT) 4.100 (AMT)

SUSPENSION	
FRONT	<b>Single cab:</b> Single stage alloy steel taper leaf springs <b>Crew cab:</b> Single stage alloy steel multi leaf springs
	Double acting hydraulic shock absorbers. Stabiliser bar.
REAR	Multi leaf main, multi leaf helper spring
	Double acting hydraulic shock absorbers. Stabiliser bar.

BRAKES	
<b>TYPE</b>	Ventilated disc/disc with dual circuit hydraulic control, integrated boost assist and electronic brake force distribution (EBD)
<b>DIAMETER FRONT</b>	310 mm
<b>DIAMETER REAR</b>	310 mm
<b>PARK BRAKE</b>	203 mm diameter drum mounted on rear of transmission
<b>AUXILIARY BRAKE</b>	Vacuum controlled exhaust brake

STEERING	
<b>TYPE</b>	Power assisted recirculating ball
<b>GEAR RATIO</b>	20.9
<b>TURNS LOCK TO LOCK</b>	5.4
<b>WHEEL LOCK ANGLE</b>	43.00° (inside wheel) 33.00° (outside wheel)

WHEELS & TYRES	
FRONT	<b>Wheels:</b> 17.5 x 6.00 six stud steel
	<b>Tyres:</b> 215/75 R17.5 126/124M Bridgestone Tubeless
	<b>Steer axle tyre rating:</b> 3,400 kg
REAR	<b>Wheels:</b> 17.5 x 6.00 six stud steel
	<b>Tyres:</b> 215/75 R17.5 126/124M Bridgestone Tubeless
	<b>Drive axle tyre rating:</b> 6,400 kg
SPARE	1 frame mounted spare wheel and tyre assembly

CHASSIS FRAME	
<b>TYPE</b>	Cold rivetted ladder frame. SAPH440 steel sidemembers. Parallel side rails and rivetless top flange.
<b>DIMENSIONS</b>	<b>Side rail (mm):</b> 216 x 70 x 6.0 <b>Rear frame width (mm):</b> 850

FUEL TANK	
<b>TYPE</b>	Frame mounted steel fuel tank
<b>CAPACITY</b>	140L
<b>FUEL CAP</b>	Lockable

ELECTRICAL SYSTEM	
<b>TYPE</b>	24 volt
<b>ALTERNATOR</b>	90 amp
<b>STARTER MOTOR</b>	4.0 kW
<b>BATTERY</b>	2 x 80D26L (630 CCA) batteries connected in series

CABIN GENERAL FEATURES	
<b>ENGINE ACCESS</b>	<b>Single cab:</b> Manual cab tilt to 45° with torsion bar assistance <b>Crew cab:</b> Access hatch under driver's seat and tiltable front passenger seat
<b>STEPS</b>	Heavy duty anti-slip steps
<b>DOORS</b>	90° opening internally reinforced front doors
<b>MIRRORS</b>	Cab mounted convex mirrors with left side under view mirror
<b>WIPERS</b>	Two speed windscreen wipers with intermittent wipe mode
<b>EXTERIOR LIGHTING</b>	Multi-reflector halogen headlamps
	Roof mounted clearance lamps
	Front foglamps
<b>AUDIBLE WARNING</b>	Reverse alarm
<b>GRILLE</b>	Cabin colour
<b>SECURITY</b>	Central locking with remote keyless entry and immobiliser

INSTRUMENTATION	
<b>MULTI INFORMATION DISPLAY</b>	AEB, FCW, DWS, LDW, TMW systems activation alerts
	<b>Single cab:</b> CTW indicator
	Low engine oil level alert (activated when oil pan < 71% capacity)
	Vehicle systems status
	Low fuel level alert
	Fuel consumption information
	Service interval alerts
<b>GENERAL INSTRUMENTATION</b>	Hourmeter
	Adjustable vehicle speed warning
	Speedometer and tachometer
	Digital odometer with integrated dual tripmeters
	Engine coolant temperature and fuel level gauges

CABIN INTERIOR	
<b>SEATING</b>	<b>Single cab:</b> Driver's bucket seat equipped with mechanical suspension and weight adjustment to 130 kg <b>Crew cab:</b> Driver's bucket seat
	Front passenger bench seat with 2 seat capacity
	<b>Crew cab:</b> Rear bench seat with 4 seat capacity
<b>SEATBELTS</b>	3-point lap sash seatbelts in all outboard seating positions. Centre seat lap belts.
<b>STEERING COLUMN</b>	Tilt/telescopic adjustable
<b>ENTRY ASSIST GRIPS</b>	Door and roof pillar mounted
	<b>Crew cab:</b> Full width rear grab rail
<b>DOOR WINDOWS</b>	Electric control
<b>STORAGE</b>	Overhead shelf
	Twin cup holders
	Front centre console box and storage tray
	Front door pockets
<b>POWER OUTLET</b>	24V cigarette lighter
<b>AIRCONDITIONING</b>	Manual control
<b>INTERIOR LIGHTING</b>	<b>Single cab:</b> Fluorescent lamp <b>Crew cab:</b> Standard lamp



Crew cabin rear

AUDIO VISUAL UNIT	
<b>SCREEN TYPE</b>	6.2" LCD with capacitive touch
<b>OPERATING SYSTEM</b>	Android
<b>RADIO</b>	AM/FM
<b>INTERNAL STORAGE CAPACITY</b>	32GB
<b>OTHER CAPABILITY</b>	Provision for external camera inputs, navigation, reverse sensors and tyre pressure monitoring



DRIVER CONTROLS	
<b>SAFETY SYSTEMS</b>	AEB on/off, DWS on/off/sensitivity adjust, LDW on/off/sensitivity adjust, TMW on/off, ESC & ASR on/off, headlamps and ALS on/off, HSA on/off/sensitivity adjust (MT only)
<b>ENGINE</b>	Idle speed control
	Cruise control
<b>TRANSMISSION (AMT ONLY)</b>	Slow/fast gear engagement control, 1st gear start and normal/economy gear selection modes
	Gear selection control with R-N-D and sequential shift positions
<b>GENERAL CONTROLS</b>	Windscreen wipers (2 speed and intermittent modes), washers, exhaust brake, turn signals



AMT model shown

WEIGHTS (kg)							
MODELS	RATINGS*		LOADING LIMIT* (at ground)		CAB CHASSIS WEIGHT #		
	GVM	GCM	FRONT	REAR	FRONT	REAR	TOTAL
NPR 450 / NPR 425	7,500 / 5,995	11,000	3,100	6,400	1,780	870	2,650
NPR 450 / NPR 425 AMT	7,500 / 5,995	11,000	3,100	6,400	1,780	870	2,650
NPR 450L / NPR425L	7,500 / 5,995	11,000	3,100	6,400	1,820	910	2,730
NPR 450L / NPR425L AMT	7,500 / 5,995	11,000	3,100	6,400	1,820	910	2,730
NPR 450 CREW	7,500	11,000	3,100	6,400	2,010	965	2,975
NPR 450 AMT CREW	7,500	11,000	3,100	6,400	2,010	965	2,975

\* Vehicle ratings and axle weight limits are subject to government regulatory requirements and weight distribution analysis. Consult your Isuzu dealer to select the correct vehicle for your specific application.

# Cab chassis only as supplied and including 10 litres of fuel.

DIMENSIONS (mm)													(m)
MODELS	WB	OAL	FOH	ROH	EA	CE	RT	ORT	CH	FFA (unladen)	RFA (unladen)	RFH (unladen)	TURNING CIRCLE kerb to kerb
NPR 450 / NPR 425	3,365	5,985	1,100	1,510	2,680	4,302	1,650	2,115	2,270	675	790	830	12.4
NPR 450L / NPR 425L	4,175	7,338	1,100	2,053	3,490	5,655	1,650	2,115	2,270	675	790	845	15.3
NPR 450 CREW	4,175	7,338	1,100	2,053	2,510	4,654	1,650	2,115	2,270	660	800	860	15.3

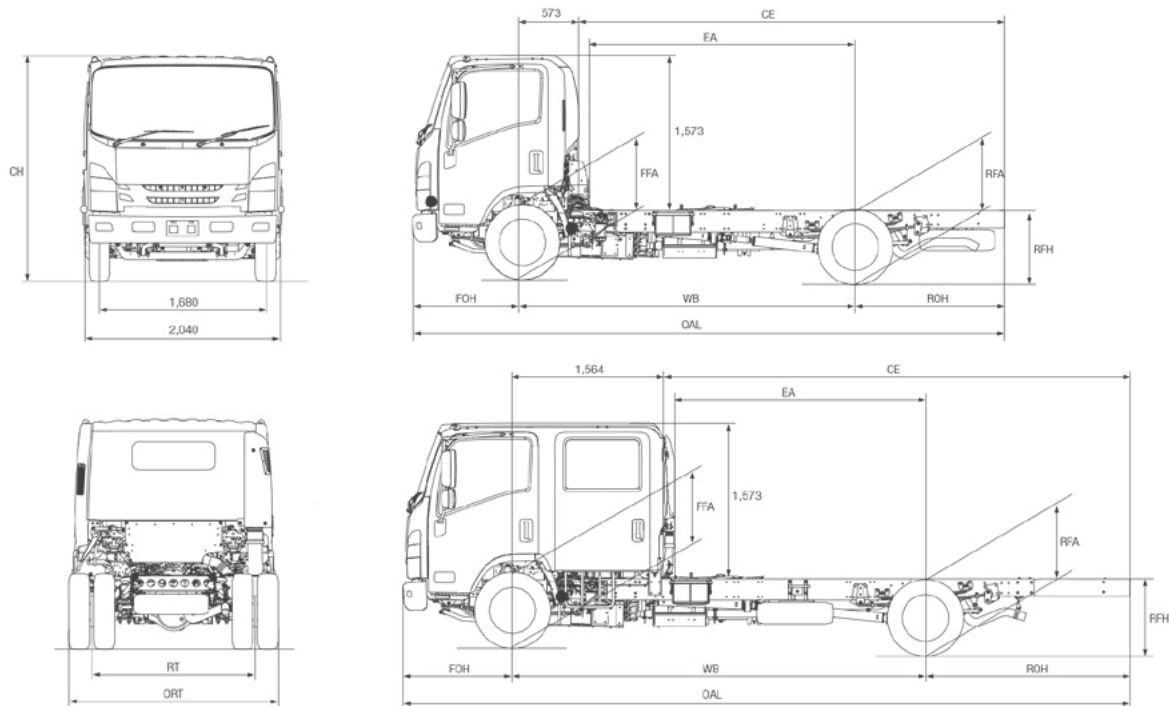

PERFORMANCE (calculated - typical paved road)				
		GEARED SPEED* (top gear at peak power engine rpm)	LOW SPEED GRADEABILITY (lowest forward gear assuming no wheel slip)	ENGINE SPEED (top gear at 90 km/h)
NPR 450	At 7,500 kg GVM	118 km/h @ 2,600 RPM	41%	1,944 rpm
NPR 450 AMT	At 7,500 kg GVM	113 km/h @ 2,600 RPM	43%	2,039 rpm

\* Maximum speed achievable depends on vehicle frontal area as well as other factors. Consult your Isuzu dealer for more detailed information.

ORDER CODES	
MODELS	CODES
450 / NPR 425	NP1318 / NP2118
NPR 450 AMT / NPR 425 AMT	NP1418 / NP2218
NPR 450L AMT / NPR425L AMT	NP1618 / NP2618
NPR 450L / NPR425L	NP1518 / NP2518
NPR 450 CREW	NP3218
NPR 450 AMT CREW	NP3318

# Total 5 Year Warranty, including Base Warranty (36 months / 100,000kms) and Additional Warranty (24 months / 150,000kms), cover is 60 months or 250,000kms, whichever comes first. To qualify for Additional Warranty, all scheduled servicing during the Base and Additional Warranty periods (ie. the total 60 months) must be performed by an authorised Isuzu service dealer from the date of delivery to the first customer. If scheduled servicing is performed by unauthorised service providers, only the Base Warranty will apply. For VL24 NPR Tipper models, additional Warranty applies to the cab & chassis only. Tipper bodies are excluded from Additional Warranty. These are covered by Base Warranty only. Cab Perforation Corrosion is limited to 36 months / unlimited kms on all models. It is not included as part of Additional Warranty. The information in this spec sheet was correct at time of printing, but all measurements, specifications and equipment are subject to change without notice. Some equipment may have been changed and/or is available at extra cost. Isuzu New Zealand (INZ) may make changes at any time without notice, in prices, colours, materials, equipment and models. INZ makes all reasonable attempts to ensure the availability of all vehicles and equipment. The information in this spec sheet is general in nature. Your Isuzu dealer can confirm all measurements, specifications and vehicle / equipment availability upon request. To the extent permitted by the law, INZ is not liable to any person as result of reliance on the content of this spec sheet.